

Software Modeling

doc. Ing. Valentino Vranić, PhD., ÚISI FIIT STU

Test – November 3, 2015

A

Priezvisko:

1b	
2b	

Meno:

1	
2	
3	
4	
5	
6	
7	
8	
9	

The test lasts 30 minutes. Write the answers to questions into the table. Only the answers in the table will be considered. In multiple-choice questions only one choice is correct. In case of making corrections, mark clearly which answer is valid. Each correct answer has the value as indicated in the question. An answer that is incorrect, ambiguous, or incomplete will be marked with 0 points. The work out is not considered. Only undamaged paper will be accepted.

1. (1 b) From the following activity diagram

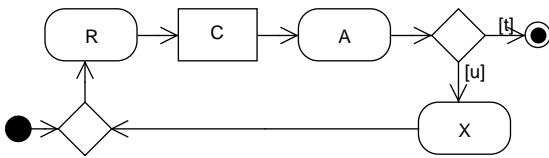

it can be concluded that the R action

- (a) would be repeated at least once
- (b) could be repeated
- (c) would be realized exactly twice
- (d) would be realized exactly once
- (e) would never be realized

2. (1 b) In activity diagrams time flow is

- (a) bottom up
- (b) left to right
- (c) not directly indicated
- (d) left to right
- (e) top down

3. (1 b) Exclusively from this sequence diagram

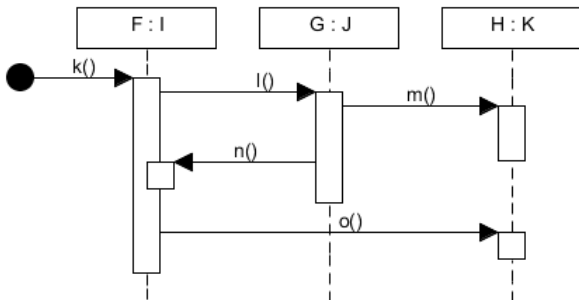

the following class diagram can be devised:

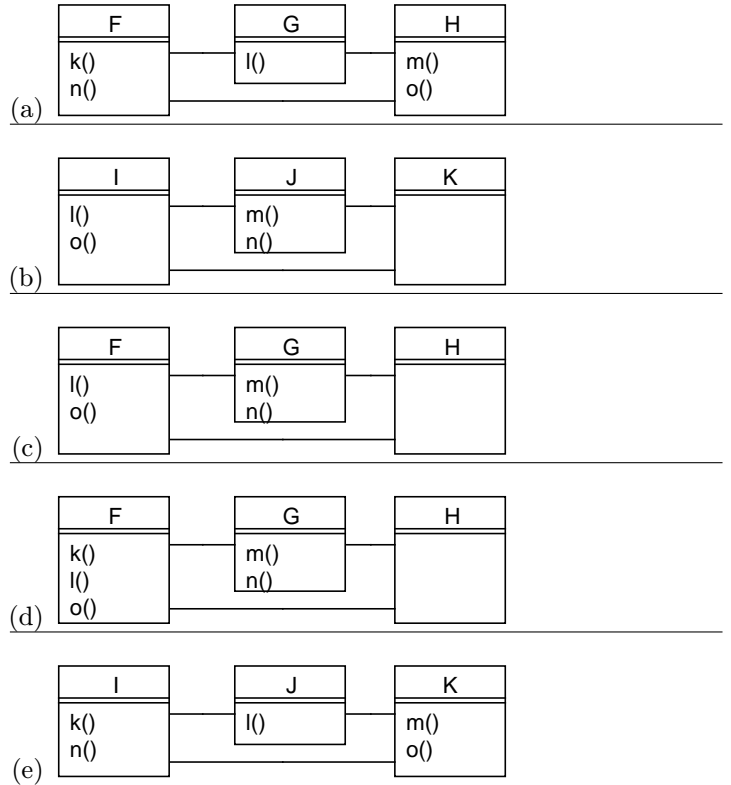

4. (1 b) The following diagram is given:

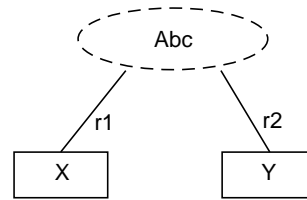

What does this diagram express?

- (a) a collaboration of the objects of the r1 and r2 type
- (b) the structure of the Abc concrete use case
- (c) the structure of the Abc abstract use case
- (d) a collaboration of the objects of the X and Y type
- (e) actors in a use case Abc

5. (1 b) In UML, a dependency between packages

- (a) implements a behavior
- (b) represents a border between the classes
- (c) realizes a behavior
- (d) prescribes and realizes a behavior
- (e) indicates a dependency among their elements

6. (1 b) Assuming that Jacobson's notation is used, the following use case diagram

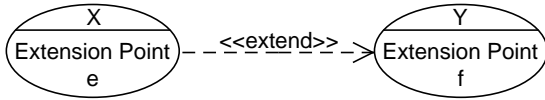

implies that

- the description of the X use case will contain the activation of the flow related to the e extension point
- the description of the Y use case will contain the activation of the flow related to the e extension point
- the description of the Y use case will contain the activation of the flow related to the f extension point
- the description of the X use case will contain the activation of the e extension point in the f extension point
- the description of the X use case will contain the activation of the flow related to the f extension point

7. (1 b) The main flow of the Dispatch Order use case, which has to be supported by the software system being developed, is given:

- The operator selects to dispatch orders.
- The system shows the orders that have not been dispatched yet.
- The operator selects the order to dispatch.
- The system shows the data about the selected order.
- The operator marks the order as dispatched.
- The system records that the order has been dispatched.
- The operator packs and dispatches the selected order.
- Any time during the use case, the operator can cancel the order dispatching by which the use case terminates.
- In case of any problems, the operator contacts the customer by e-mail or phone.
- The use case terminates.

Is it necessary to correct or omit some steps in this use case? If so, then which ones?

8. (2 b) Among other things, an application for time planning enables to plan an event within which a user enters the event name and time in which it will be happening. The application also enables to cancel an event or to mark it as unrealized. A use case diagram that corresponds best to this description is (use case names are abbreviated: VU = Create Event; OUN = Mark Event as Unrealized; ZU = Cancel Event; ZNU = Provide New Event Name; ZCU = Provide Event Time):

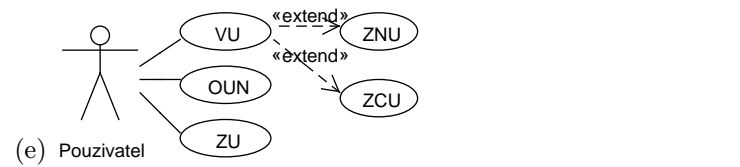
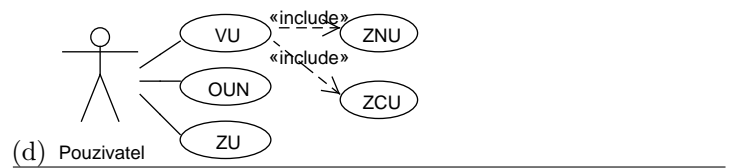
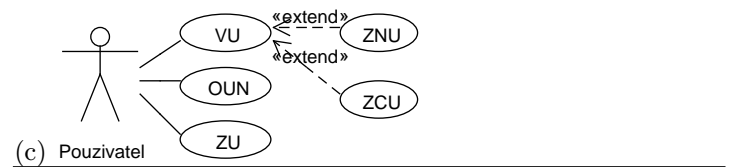
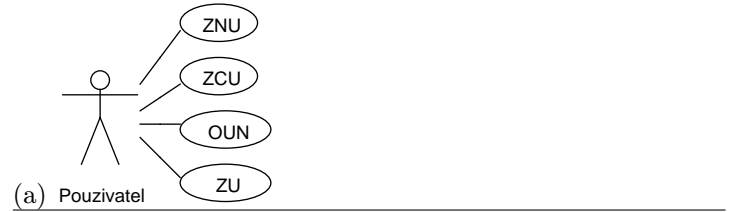

9. (1 b) In the following situation

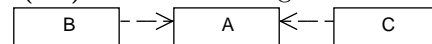

- there can't be an interface at the place of A
- there can be an interface at the place of A only if B and C have a common supertype
- there can be an interface at the place of A
- there can be an interface at the place of A only if B and C are interfaces, too
- there can't be a class at the place of A

Software Modeling

doc. Ing. Valentino Vranić, PhD., ÚISI FIIT STU
Test – November 3, 2015

A

10 b

1 b

2 c

3 e

4 d

5 e

6 e

7 yes: 7 and 9

8 b

9 c